



ashton bulk

materials handling

TRAIN UNLOADING SYSTEMS

EQUIPMENT PORTFOLIO

AB Tipplers for the Worldwide Market

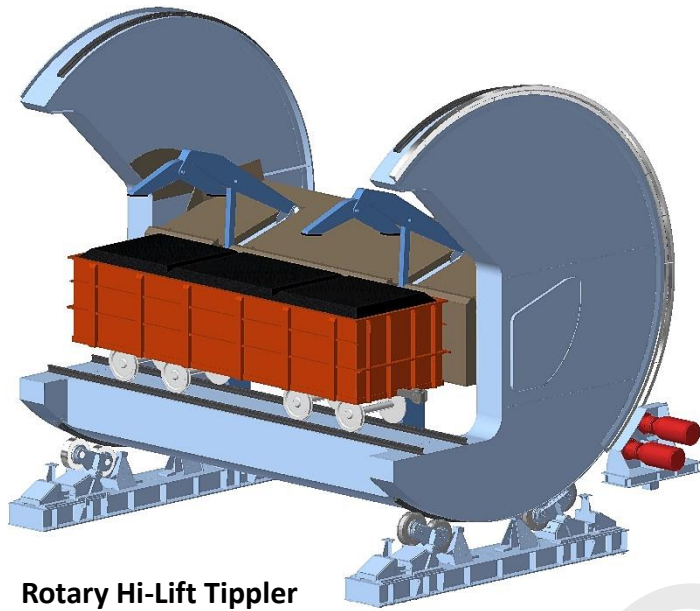

Rotary Hi-Lift Tippler

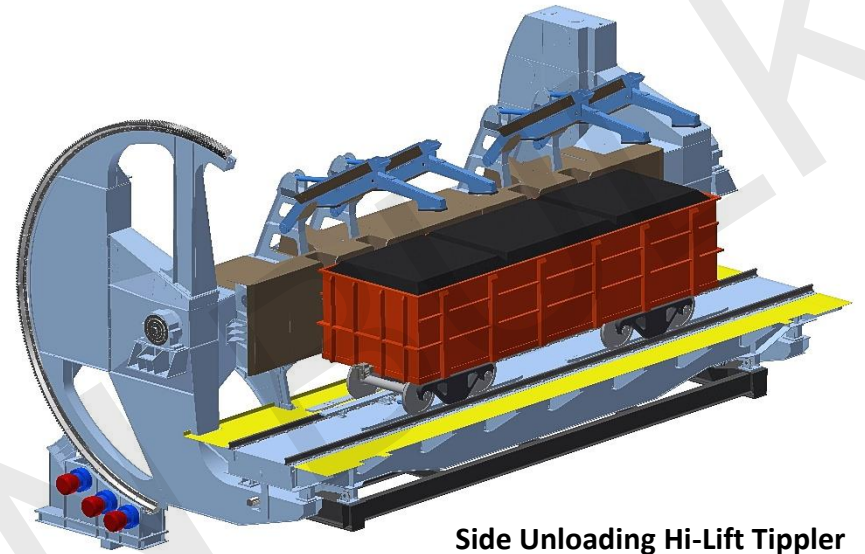

Side Unloading Hi-Lift Tippler

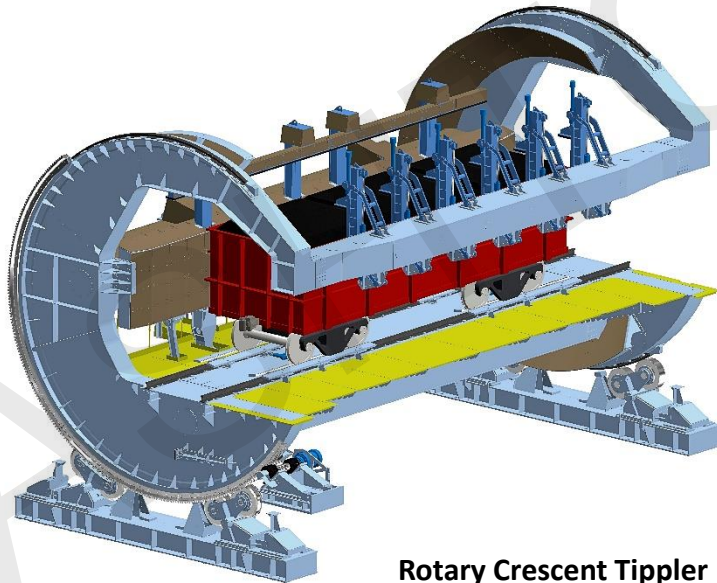

Rotary Crescent Tippler

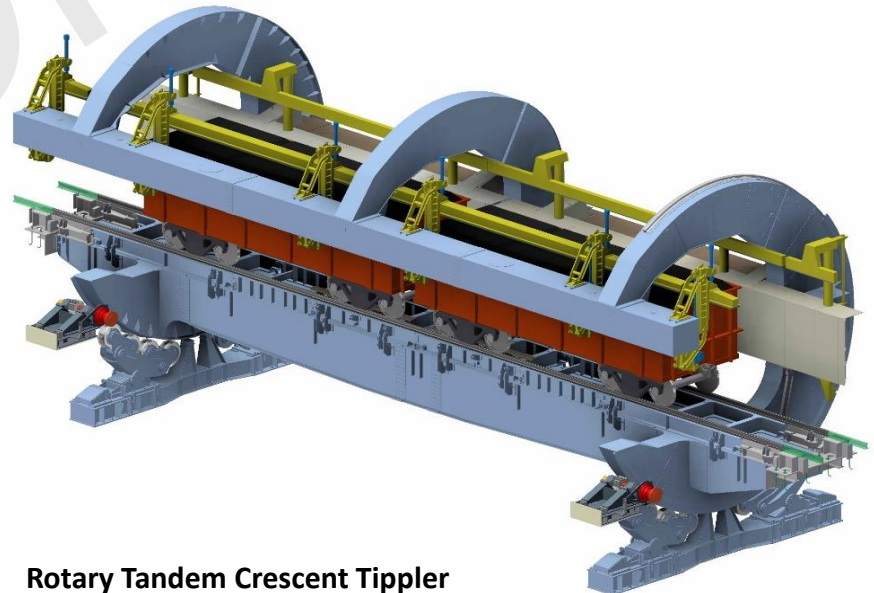

Rotary Tandem Crescent Tippler

**AB High Capacity Unit Train Tipplers for
Up to 6 Million Cycle / +25 Year Life**

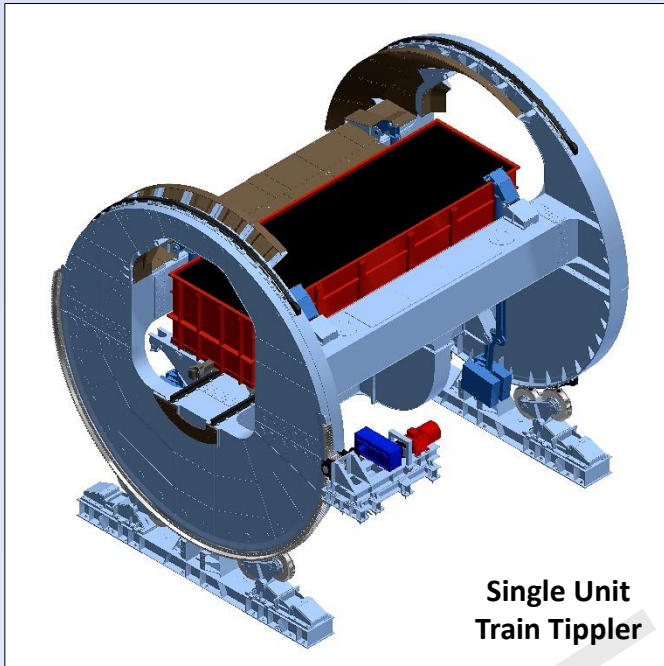

**Single Unit
Train Tippler**

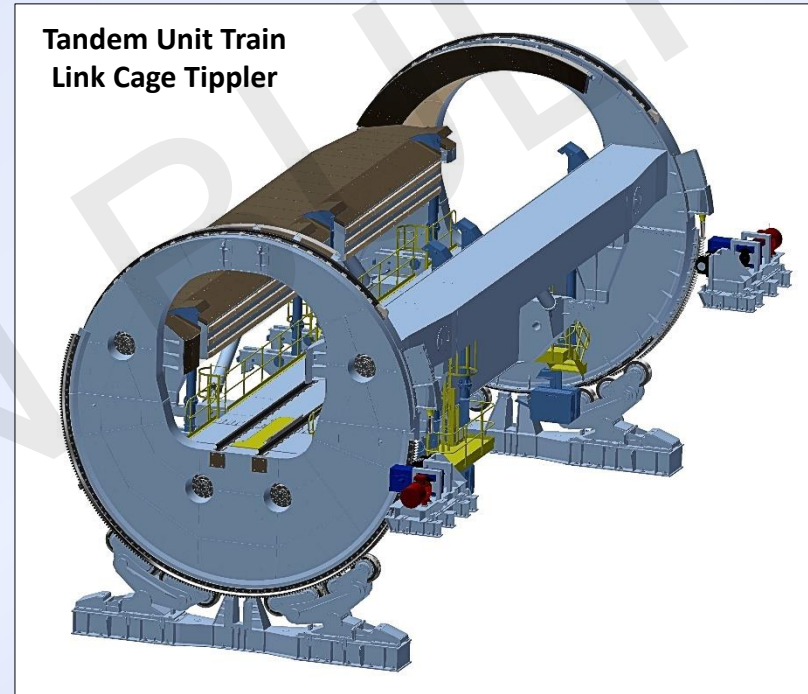

**Tandem Unit Train
Link Cage Tippler**

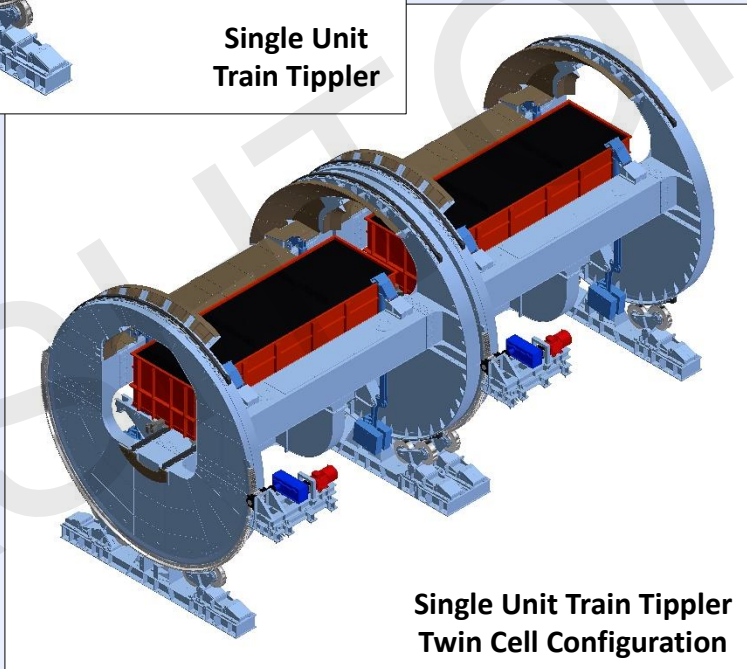

**Single Unit Train Tippler
Twin Cell Configuration**

**AB Train Moving Equipment
Positioners / Side Arm Chargers**

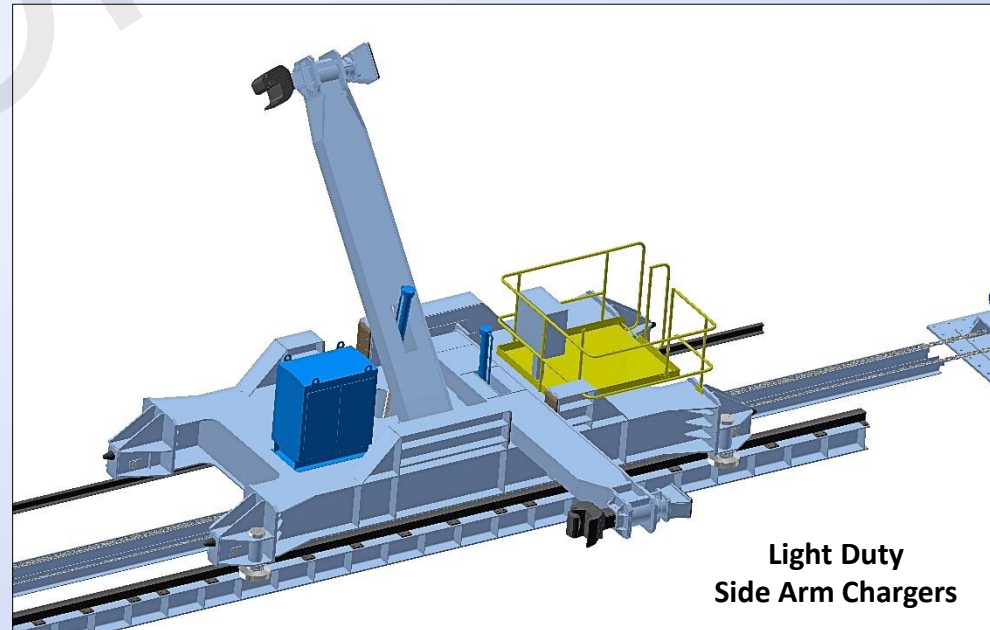
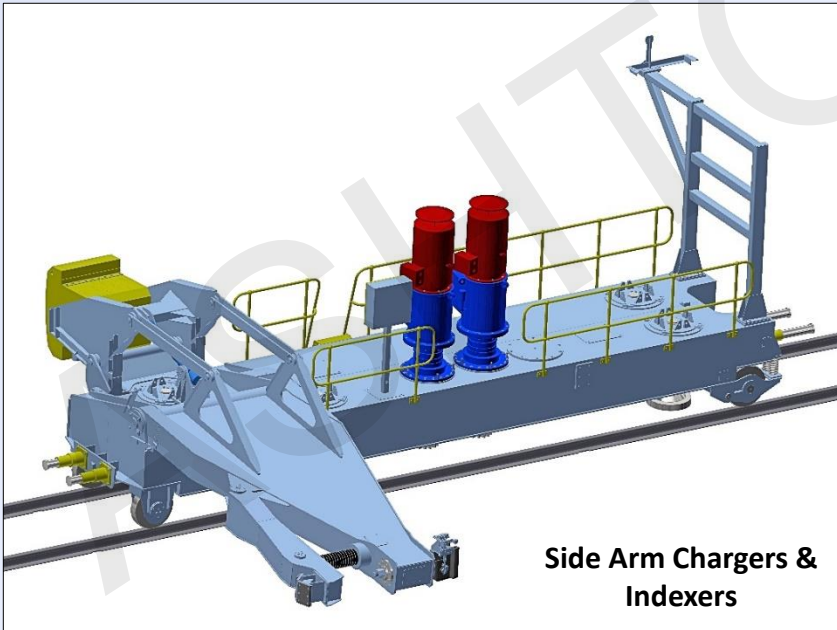
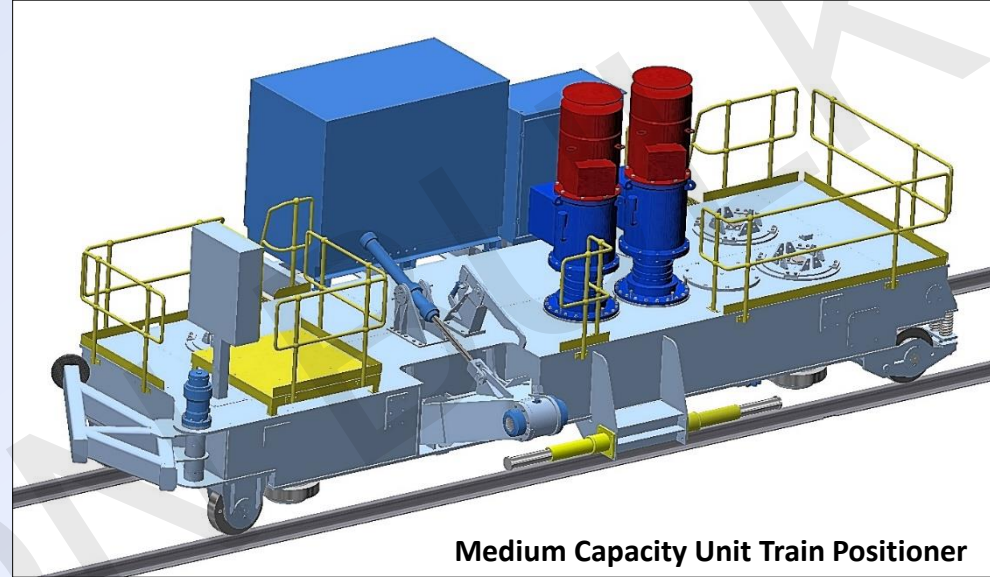
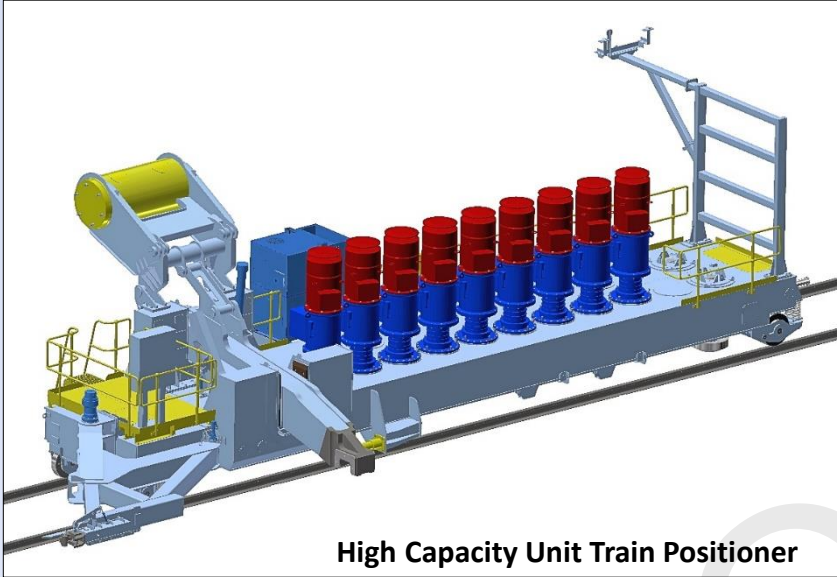

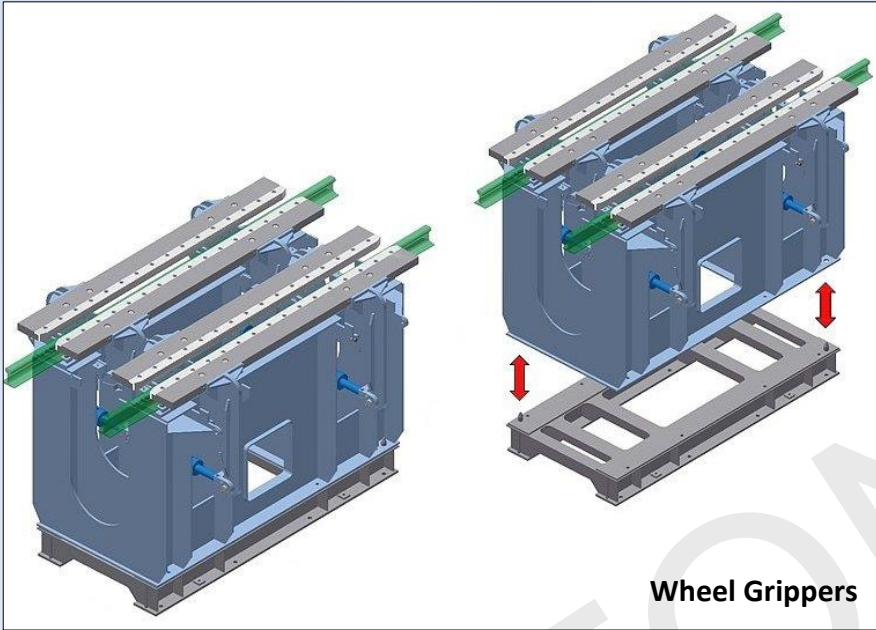

Wheel Grippers

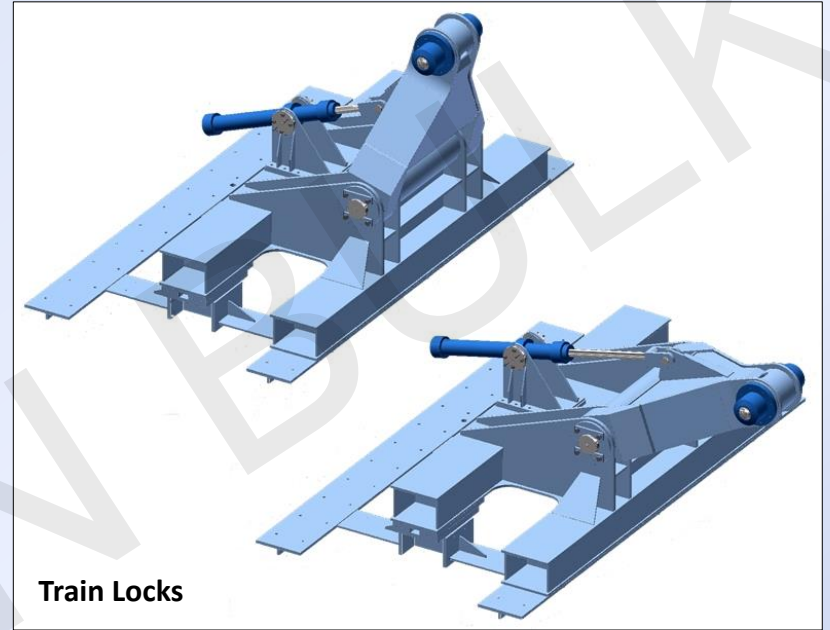

Train Locks

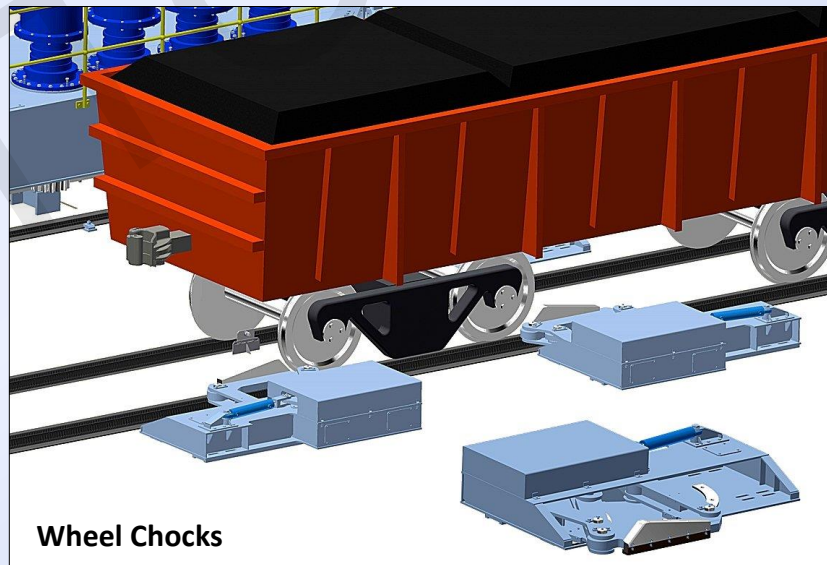

Wheel Chocks

